

Type 157...; Oberteil 110 mm
Type 158...; Oberteil 110 mm
Type 159...; Oberteil 110 mm

Armaturen für Schiffbau und Industrie
 Valves for shipbuilding and industry



Maschinethermometer aus Aluminium,
 messingfarben eloxiert
 DIN 16181 B/16182 B, Oberteil 110 x 30 mm
 Anschluss G 1/2" oder M 20 x 1,5

machine thermometers in aluminium,
 brass coloured anodized
 DIN 16181 B/16182 B, bonnet 110 x 30 mm
 connection G 1/2" or M 20 x 1,5

Temperaturbereiche:

0 / + 60° C 0 / + 160° C
 0 / + 100° C 0 / + 200° C
 0 / + 120° C

temperature ranges:

0 / + 60° C 0 / + 160° C
 0 / + 100° C 0 / + 200° C
 0 / + 120° C

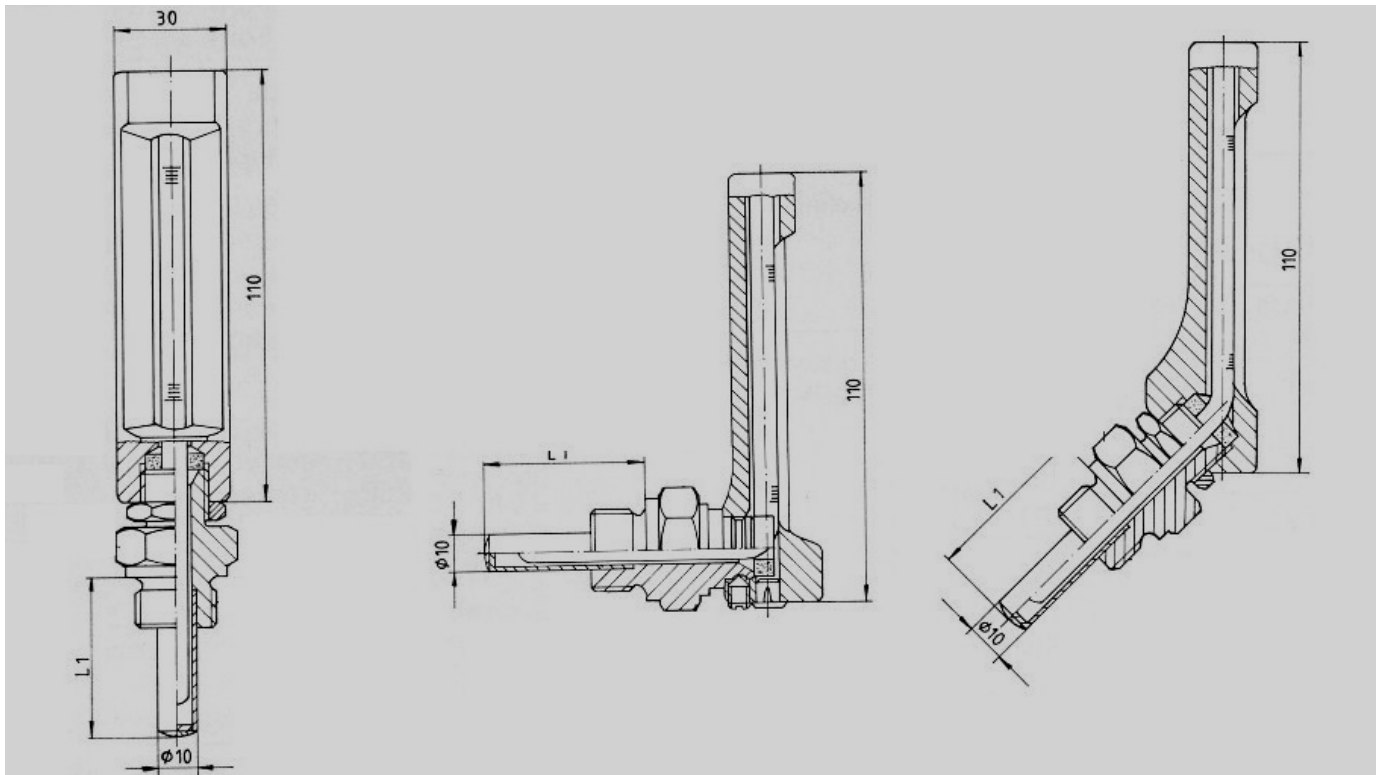

Type 157...

Type 158...

Type 159...

Die Thermometer können nach folgenden Einteilungen unterschieden werden.
 The thermometers can be diverted into the following attributes:

Artikelziffer 1: article digit 1:	Artikelziffer 2: article digit 2:	Artikelziffer 3: article digit 3:	Artikelziffer 4: article digit 4:	Artikelziffer 5: article digit 5:	Artikelziffer 6: article digit 6:
		Ausführung: execution:	Material: material:	Oberteillänge: length of bonnet:	Taucherlänge: (L1) length of diver: (L1)
1	5	7 = gerade	0 = Aluminium/Messing	0 = 110 mm	0 = 30 mm
1	5	8 = Eckform 90°	1 = Aluminium/Niro	1 = 150 mm	1 = 40 mm
1	5	9 = Eckform 135°	2 = Aluminium/CuNiFe	2 = 200 mm	2 = 63 mm
1	5				3 = 100 mm
1	5	7 = straight	0 = aluminium/brass		4 = 160 mm
1	5	8 = angle type 90°	1 = aluminium/st. steel		5 = 250 mm
1	5	9 = angle type 135°	2 = aluminium/CuNiFe		6 = 400 mm